

TRG 350

AIR-COOLED MIG GUN

Replacement Suitable for Tregaskiss®

RATING	GUN ORDERING PART NUMBER	GUN PLUG Direct Connect
350 Amp CO2 @ 80% Duty Cycle 250 Amp Mixed Gas @ 80% Duty Cycle Wire Capacity: 0.030" (0.8mm) - 0.062" (1.6mm)	R30xx-35 RB30xx-35 RE30xx-35 RLN30xx-35 RLF30xx-35 RLPM30xx-35 RM30xx-35 RPA30xx-35	Tweco® #4 Bernard® Euro Lincoln® "LN" Linc.® LF/Powerfeed 10 Lincoln® Power MIG® Miller® Panasonic®
	xx = Standard lengths of 10, 12, 15, 20 and 25 ft. Custom lengths also available.	

#	Part Number	Description
1.	R401-4-38 R401-4-50 R401-4-62 R401-4-75 R401-8-62 R401-42-50 R401-48-50	Nozzle, 3/8", Flush Tip Nozzle, 1/2", 1/8" Tip Recess Nozzle, 5/8", 1/8" Tip Recess Nozzle, 3/4", 1/8" Tip Recess Nozzle, 5/8", 1/8" Tip Stickout, Short Arc Nozzle, 1/2", Bottleneck, 1/8" Tip Recess Nozzle, 1/2", Bottleneck, 1/8" Tip Stickout
	R401-5-50 R401-5-62 R401-5-75	Nozzle, H.D., 1/2", 1/4" Tip Recess Nozzle, H.D., 5/8", 1/4" Tip Recess Nozzle, H.D., 3/4", 1/4" Tip Recess
	R401-6-50 R401-6-62 R401-6-75	Nozzle, H.D., 1/2", 1/8" Tip Recess Nozzle, H.D., 5/8", 1/8" Tip Recess Nozzle, H.D., 3/4", 1/8" Tip Recess
	R401-7-62 R401-7-75 R401-7-87	Nozzle, H.D., 5/8", 1/4" Tip Recess, Brass Nozzle, H.D., 3/4", 1/4" Tip Recess, Brass Nozzle, H.D., 7/8", 1/4" Tip Recess, Brass
2.	CMI "Taper-LOCK" Contact Tips 155-1-030 155-1-035 155-1-040 155-1-045 155-1-364 155-1-052 155-1-062	H.D. Contact Tip, .030" (0.8mm) H.D. Contact Tip, .035" (0.9mm) H.D. Contact Tip, .040" (1.0mm) H.D. Contact Tip, .045" (1.2mm) H.D. Contact Tip, 3/64" (1.2mm) H.D. Contact Tip, .052" (1.4mm) H.D. Contact Tip, .062" (1.6mm)
3.	155-2-030 155-2-035 155-2-040 155-2-045 155-2-364 155-2-052 155-2-062	H.D. Tapered Contact Tip, .030" (0.8mm) H.D. Tapered Contact Tip, .035" (0.9mm) H.D. Tapered Contact Tip, .040" (1.0mm) H.D. Tapered Contact Tip, .045" (1.2mm) H.D. Tapered Contact Tip, 3/64" (1.2mm) H.D. Tapered Contact Tip, .052" (1.4mm) H.D. Tapered Contact Tip, .062" (1.6mm)
4.	154-R505	Diffuser H.D., for Taper-LOCK™ Tip
5.	154-1	Replacement Retaining Ring
6.	154-2	Replacement O-Ring
7.	154-R506	Diffuser, for Taper-LOCK™ Tip
8.	154-1	Replacement Retaining Ring
9.	154-2	Replacement O-Ring
10.	R402-11	Gooseneck Insulator
11.	R305-45 R305-60	Gooseneck w/ Body, 45° Gooseneck w/ Body, 60°
12.	R407	Replacement Body
13.	R407-2	Body Screw

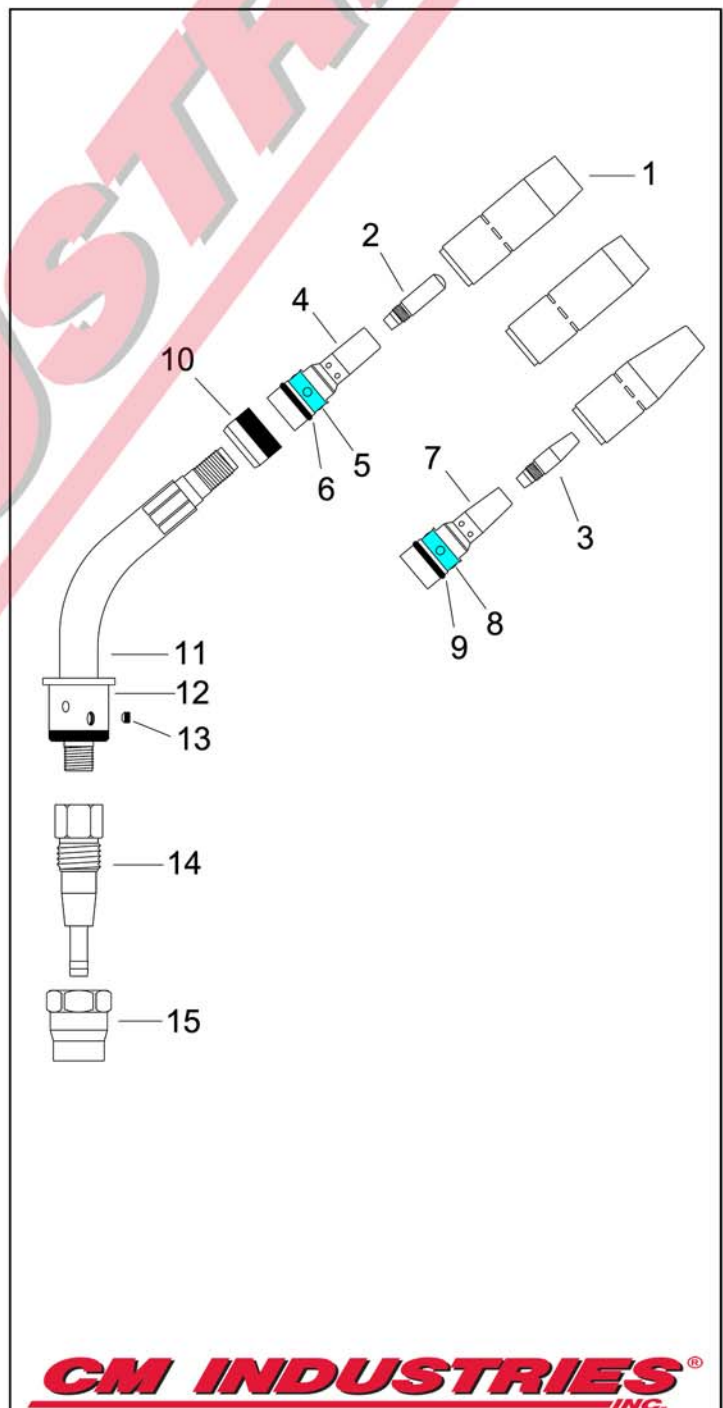

CM INDUSTRIES
INC.

COPYRIGHT © 2015 CM INDUSTRIES, INC. ALL RIGHTS RESERVED

#	Part Number	Description
14.	R408	Connector Cone
15.	R409	Cone Nut
16.	R413-5	Inner Tube Clamp
17.	R412-1	Switch Lead Connector
18.	R413-1	Outer Jacket Clamp
19.	R411-3	Mounting Screw
20.	R411-2	Switch Housing
21.	R411-1	Switch
22.	R410	Handle, Front & Rear
23.	R413-2	Spring Guard, Front & Rear
24.	R313-10	Unicable Assembly w/ Handles, 10'
	R313-12	Unicable Assembly w/ Handles, 12'
	R313-15	Unicable Assembly w/ Handles, 15'
	R313-20	Unicable Assembly w/ Handles, 20'
	R313-25	Unicable Assembly w/ Handles, 25'
25.	R416-5	Control Housing
26.	R414-400	Power Pin Block
27.	R214	Power Pin, Tweco
28.	R414-1	O-Ring
29.	C44C	Liner Set Screw
30.	R214-6-116	Power Pin, Miller
31.	R414-11-2	O-Ring, Miller
32.	R414-116	Guide Cap, Miller .035"-1/16" Wire
33.	R214-2	Power Pin, Lincoln
34.	401-00-001	Adaptor Nut
35.	285-03-002	Male Pin w/ Lead
36.	R425-10CM	Power Pin, Euro
37.	285-00-002	O-Ring, Euro
38.	300-05-001	Electrical Plug, Miller
39.	300-05-002	Electrical Plug, Lincoln
40.	R415-23-15	Liner Assembly, .023", 15'
	R415-30-15	Liner Assembly, .030", 15'
	R415-35-15	Liner Assembly .035"-.045", 15'
	R415-116-15	Liner Assembly .045"-1/16", 15'
	R415-35-2	Liner Assembly .035"-3/64", 15' Aluminum
	R415-116-2	Liner Assembly 3/64"-1/16", 15' Aluminum
	R415-35-0	Teflon Liner Assy., .035"-3/64", 15' Aluminum
	R415-116-0	Teflon Liner Assy., 3/64"-1/16", 15' Aluminum
	R415-35-25	Liner Assembly .035"-.045", 25'
	R415-116-25	Liner Assembly .045"-1/16", 25'

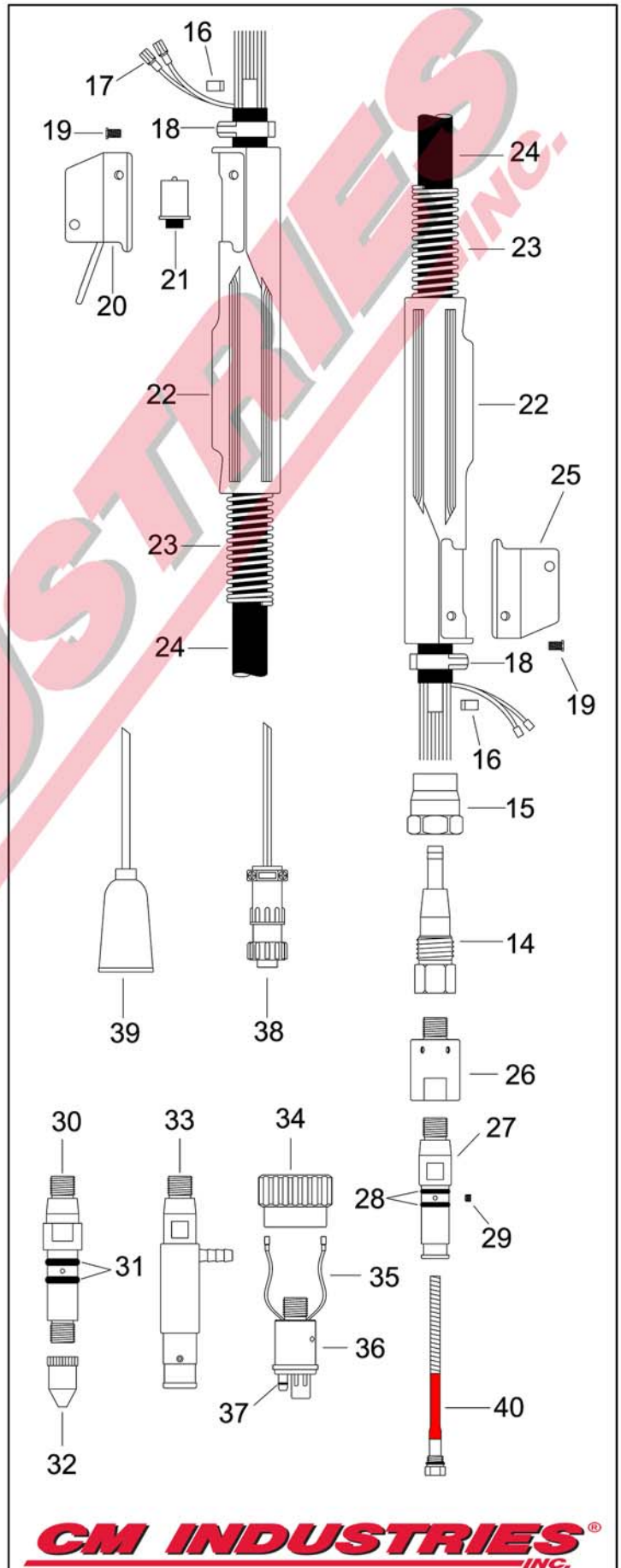

WARNING!

Please read all Safety Instructions



WARNING

- Read and follow the manufacturer's instructions, employer's safety practices, and Material Safety Data Sheets (MSDSs).
- Only qualified personnel should install, use, or service this material and/or equipment.



ELECTRIC SHOCK can kill.

- Always wear dry insulating gloves.
- Do not touch live electrical parts.
- Always disconnect power source before hooking up or changing electrodes, nozzles and other parts.



WELDING SPARKS can cause fire or explosion

- Do not weld near flammable material.
- Do not weld on closed containers.
- Remove combustibles from the work area and/or provide a fire watch.
- Avoid oily or greasy clothing as a spark may ignite them.



LOUD NOISE can damage hearing.

- Always wear protective hearing devices to ensure protection when noise levels exceed OSHA standards.



ARC RAYS can injure eyes and burn skin.

- Always wear correct eye, ear, and body protection.
- Always wear a welding helmet with the proper grade filter lens. Protect yourself and others from spatter arc rays by using protective screens, barriers and welding curtains.
- Always wear protective gloves and clothing to cover exposed skin. This will aid in the prevention of arc and spatter burns.



FUMES AND GASES can be hazardous to your health.

- Keep your head out of the fumes.
- Use enough ventilation or exhaust at the arc to keep fumes and gases from your breathing zone, and general area.
- Fumes from cutting and welding can deplete air quality, causing injury or death. Always wear an air supplied respirator in confined areas, or if breathing air is not safe.

Read American National Standard Z49.1, "Safety in Welding, Cutting, and Allied Processes," available from American Welding Society, 550 N.W. LeJeune Rd., Miami, FL 33126;

OSHA Safety and health standards, available from U.S. Government Printing Office, Washington DC 20402

CM INDUSTRIES[®]

INC.

505 OAKWOOD RD. LAKE ZURICH, IL 60047 USA

PHONE: 847-550-0033 FAX: 847-550-0444

www.cmindustries.com