

TRG 400AUTO

AIR-COOLED MIG GUN

Replacement Suitable for Tregaskiss®

RATING	GUN ORDERING PART NUMBER	GUN PLUG Direct Connect
400 Amp CO2 @ 100% Duty Cycle 300 Amp Mixed Gas @ 100% Duty Cycle Wire Capacity: 0.035" (0.9mm) - 5/64" (2.0mm)	R41xx-45 RE41xx-45 RLN41xx-45 RLF41xx-45 RLP41xx-45 RM41xx-45 RPA41xx-45	Tweco® #4 Euro Lincoln® "LN" Linc.® LF/Powerfeed 10 Lincoln® Power MIG® Miller® Panasonic®
	xx = Standard lengths of 4, 6, 8 and 10 ft. Custom lengths also available.	

#	Part Number	Description
1.	R401-4-38	Nozzle, 3/8", Flush Tip
	R401-4-50	Nozzle, 1/2", 1/8" Tip Recess
	R401-4-62	Nozzle, 5/8", 1/8" Tip Recess
	R401-4-75	Nozzle, 3/4", 1/8" Tip Recess
	R401-41-50	Nozzle, 1/2", Extended Reach
	R401-42-50	Nozzle, 1/2", Bottleneck, 1/8" Tip Recess
	R401-48-50	Nozzle, 1/2", Bottleneck, 1/8" Tip Stickout
	R401-5-50	Nozzle, H.D., 1/2", 1/4" Tip Recess
	R401-5-62	Nozzle, H.D., 5/8", 1/4" Tip Recess
	R401-5-75	Nozzle, H.D., 3/4", 1/4" Tip Recess
	R401-6-50	Nozzle, H.D., 1/2", 1/8" Tip Recess
	R401-6-62	Nozzle, H.D., 5/8", 1/8" Tip Recess
	R401-6-75	Nozzle, H.D., 3/4", 1/8" Tip Recess
	R401-7-62	Nozzle, H.D., 5/8", 1/4" Tip Recess, Brass
	R401-7-75	Nozzle, H.D., 3/4", 1/4" Tip Recess, Brass
	R401-7-87	Nozzle, H.D., 7/8", 1/4" Tip Recess, Brass
	R401-8-62	Nozzle, 5/8", 1/8" Tip Stickout, Short Arc
	R401-81-62	Nozzle, H.D., 5/8", 1/8" Tip Stickout, Short Arc
	2.	CMI "Taper-LOCK" Contact Tips
155-1-030		H.D. Contact Tip, .030" (0.8mm)
155-1-035		H.D. Contact Tip, .035" (0.9mm)
155-1-040		H.D. Contact Tip, .040" (1.0mm)
155-1-045		H.D. Contact Tip, .045" (1.2mm)
155-1-364		H.D. Contact Tip, 3/64" (1.2mm)
155-1-052		H.D. Contact Tip, .052" (1.4mm)
155-1-062		H.D. Contact Tip, .062" (1.6mm)
155-1-564		H.D. Contact Tip, 5/64" (2.0mm)
155-1-332		H.D. Contact Tip, 3/32" (2.4mm)
3.		155-2-030
	155-2-035	H.D. Tapered Contact Tip, .035" (0.9mm)
	155-2-040	H.D. Tapered Contact Tip, .040" (1.0mm)
	155-2-045	H.D. Tapered Contact Tip, .045" (1.2mm)
	155-2-364	H.D. Tapered Contact Tip, 3/64" (1.2mm)
	155-2-062	H.D. Tapered Contact Tip, .062" (1.6mm)
4.	154-R505	Diffuser H.D., for Taper-LOCK™ Tip
	154-1	Replacement Retaining Ring
5.	154-1	Replacement Retaining Ring
	154-2	Replacement O-Ring
7.	154-R506	Diffuser, for Taper-LOCK™ Tip
	154-1	Replacement Retaining Ring
8.	154-1	Replacement Retaining Ring
	154-2	Replacement O-Ring
10.	R402-11	Gooseneck Insulator

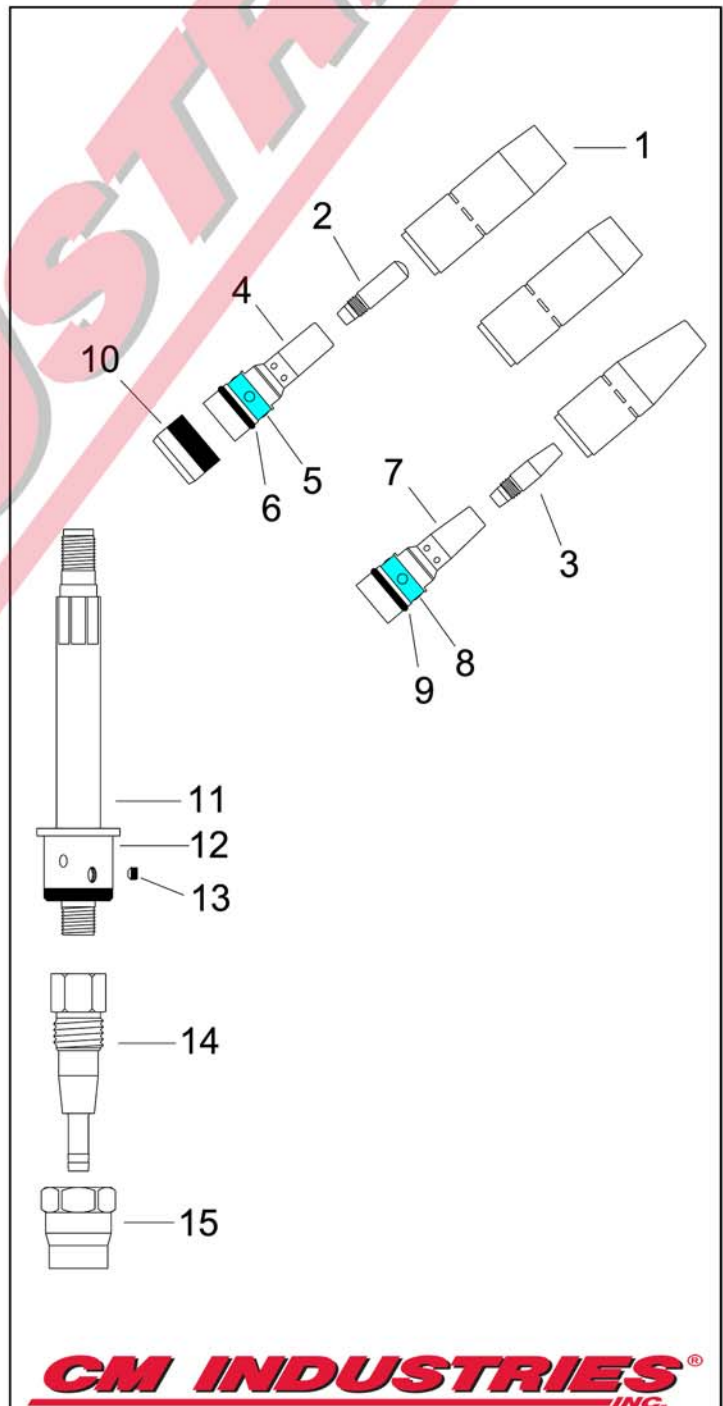

CM INDUSTRIES
INC.

COPYRIGHT © 2015 CM INDUSTRIES, INC. ALL RIGHTS RESERVED

#	Part Number	Description
11.	R405-180	Gooseneck w/ Body, 180°, Std.
	R405-22	Gooseneck w/ Body, 22°
	R405-45	Gooseneck w/ Body, 45°
	R405-60	Gooseneck w/ Body, 60°
12.	R407	Replacement Body
13.	R407-2	Body Screw
14.	R408	Connector Cone
15.	R409	Cone Nut
16.	R413-5	Inner Tube Clamp
17.	R413-1	Outer Jacket Clamp
18.	R410-11	Mounting Screw, Automatic
19.	R410-10	Front Housing, Automatic
20.	R413-2	Spring Guard, Front & Rear
21.	R413-04	Unicable Assembly w/ Handles, 4'
	R413-06	Unicable Assembly w/ Handles, 6'
	R413-08	Unicable Assembly w/ Handles, 8'
	R413-10	Unicable Assembly w/ Handles, 10'
22.	R410	Handle, Rear
23.	R416-5	Control Housing
24.	R411-3	Mounting Screw
25.	R414-400	Power Pin Block
26.	R214	Power Pin, Tweco
27.	R414-1	O-Ring
28.	C44C	Liner Set Screw
29.	R214-1	Power Pin, Miller
30.	R414-11-2	O-Ring, Miller
31.	R414-116	Guide Cap, Miller .035"-1/16" Wire
	R414-332	Guide Cap, Miller 5/64"-3/32" Wire
32.	R214-2	Power Pin, Lincoln
33.	401-00-001	Adaptor Nut
34.	285-03-002	Male Pin w/ Lead
35.	R425-10CM	Power Pin, Euro
36.	285-00-002	O-Ring, Euro
37.	300-05-001	Electrical Plug, Miller
38.	300-05-002	Electrical Plug, Lincoln
39.	R415-35-6	Liner Assembly .035"-.045", 6'
	R415-116-6	Liner Assembly .045"-1/16", 6'
	R415-35-15	Liner Assembly .035"-.045", 15'
	R415-116-15	Liner Assembly .045"-1/16", 15'
	R415-564-15	Liner Assembly, 1/16-5/64", 15'
	R415-332-15	Liner Assembly, 5/64-3/32", 15'
	R415-35-2	Liner Assembly .035"-3/64", 15' Aluminum
	R415-116-2	Liner Assembly 3/64"-1/16", 15' Aluminum
	R415-35-0	Teflon Liner Assy., .035"-3/64", 15' Aluminum
	R415-116-0	Teflon Liner Assy., 3/64"-1/16", 15' Aluminum

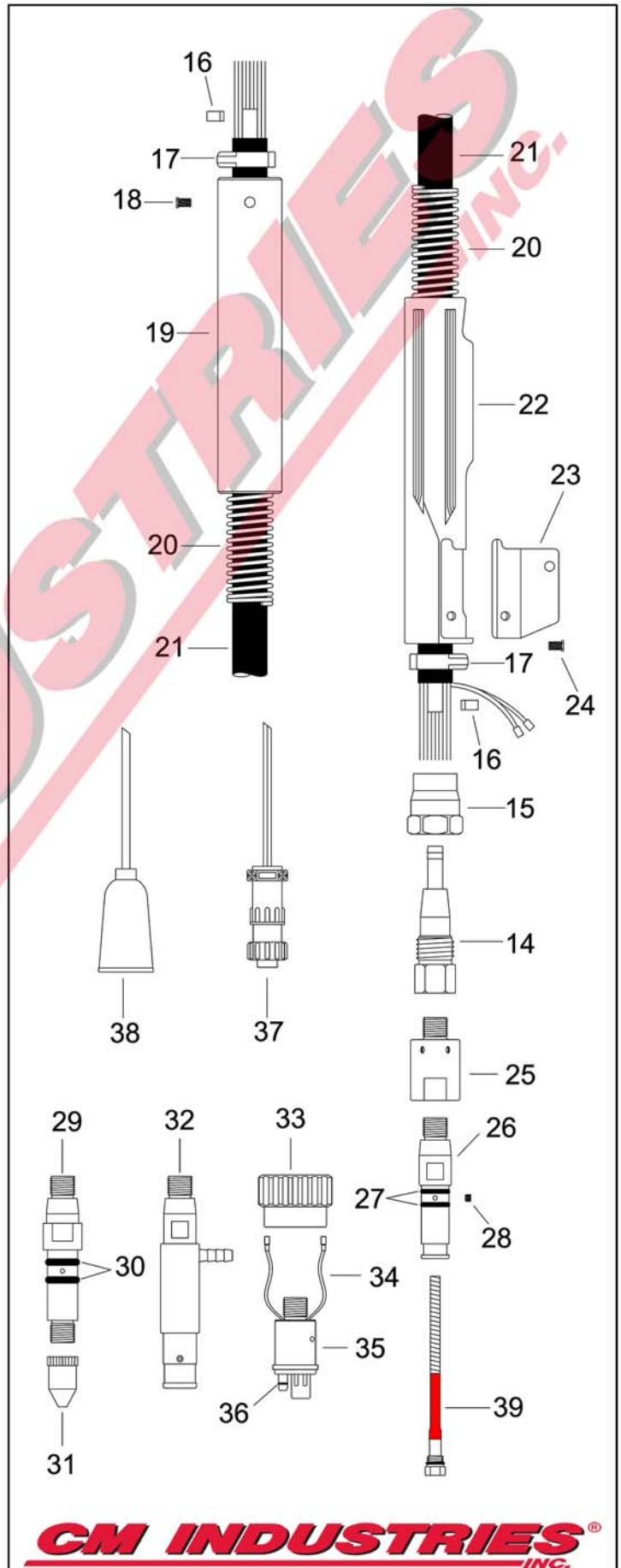

WARNING!

Please read all Safety Instructions



WARNING

- Read and follow the manufacturer's instructions, employer's safety practices, and Material Safety Data Sheets (MSDSs).
- Only qualified personnel should install, use, or service this material and/or equipment.



ELECTRIC SHOCK can kill.

- Always wear dry insulating gloves.
- Do not touch live electrical parts.
- Always disconnect power source before hooking up or changing electrodes, nozzles and other parts.



WELDING SPARKS can cause fire or explosion

- Do not weld near flammable material.
- Do not weld on closed containers.
- Remove combustibles from the work area and/or provide a fire watch.
- Avoid oily or greasy clothing as a spark may ignite them.



LOUD NOISE can damage hearing.

- Always wear protective hearing devices to ensure protection when noise levels exceed OSHA standards.



ARC RAYS can injure eyes and burn skin.

- Always wear correct eye, ear, and body protection.
- Always wear a welding helmet with the proper grade filter lens. Protect yourself and others from spatter arc rays by using protective screens, barriers and welding curtains.
- Always wear protective gloves and clothing to cover exposed skin. This will aid in the prevention of arc and spatter burns.



FUMES AND GASES can be hazardous to your health.

- Keep your head out of the fumes.
- Use enough ventilation or exhaust at the arc to keep fumes and gases from your breathing zone, and general area.
- Fumes from cutting and welding can deplete air quality, causing injury or death. Always wear an air supplied respirator in confined areas, or if breathing air is not safe.

Read American National Standard Z49.1, "Safety in Welding, Cutting, and Allied Processes," available from American Welding Society, 550 N.W. LeJeune Rd., Miami, FL 33126;

OSHA Safety and health standards, available from U.S. Government Printing Office, Washington DC 20402

CM INDUSTRIES[®]

INC.

505 OAKWOOD RD. LAKE ZURICH, IL 60047 USA

PHONE: 847-550-0033 FAX: 847-550-0444

www.cmindustries.com